

8.2. Pinhole camera

Introduction

The pinhole camera is a simple device which allows light to pass only through a very small hole of the size of a pin tip. By putting a screen (flat surface) at a distance from this hole, you can see the image of an object (present in front of the pinhole on other side) on the screen. If the screen is a thin translucent sheet, then the image can be observed on both sides of screen. See figure 1 below.

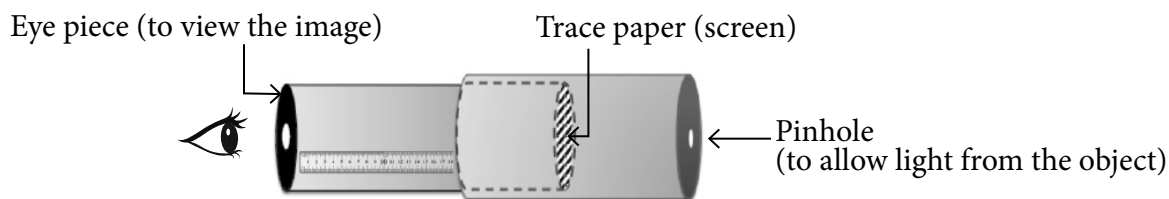

Figure 1 Schematic of pinhole camera that also acts as a measuring device

In this unit, you will make a pinhole camera and use it as a measurement device. You will also understand how an image is formed by a pinhole.

Task 1: Making a pinhole camera

Materials: Black chart paper, tracing paper/translucent polythene sheet, printed ruler on paper or graph paper, measuring tape, scissors, adhesive, cutter, sticky tape, aluminium foil used in kitchen

This stage is one of making and the task is to come up with a working pinhole camera. Instructions for making are given below.

- i. Cut a rectangular piece from the black chart paper and roll into a hollow tube. Secure with sticky tape or with rubber bands so that the tube is firm. The diameter should be approximately 3 cm and height 25 cm.



Figure 2(a) Rolling chart paper

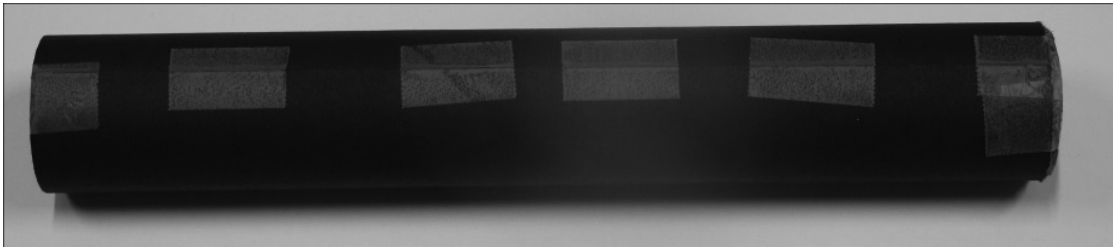

Figure 2(b) *Chart paper as pipe*

You can also vary the diameter and length of the tube. Smaller diameter will increase the clarity of the image. (One can also use the discarded cardboard tubes used for packaging on which aluminium foil or kitchen paper tissue are rolled.)

- ii. Cover the other end of the tube with a translucent sheet of tracing paper or a similar material. This sheet will work as the screen. Let us call this tube as the image tube (IT). Put the markings on the screen as shown in figure 3 at every 5 mm. The markings will help in measuring the size of the image formed on the screen in task 3.

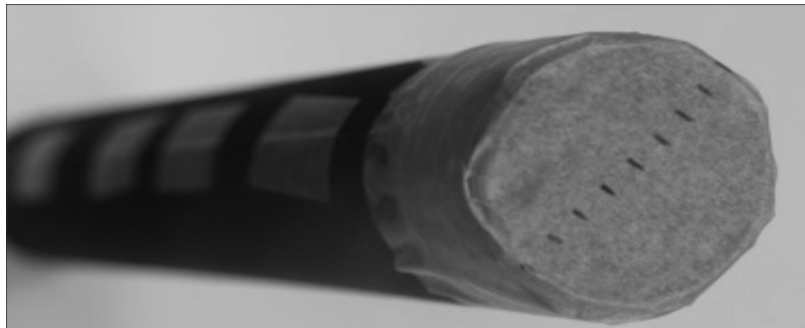

Figure 3 *Markings on screen for measuring image size*

- iii. Fold another rectangular chart paper into a cylindrical tube such that it is smaller in length and slightly larger in diameter than the IT, so that the IT can slide inside smoothly. Cover one end of this tube with a circular black chart paper or aluminium foil and make a hole in the centre using a pin (aluminium foil is slightly easier to work with). We will call this tube the pinhole tube (PT).

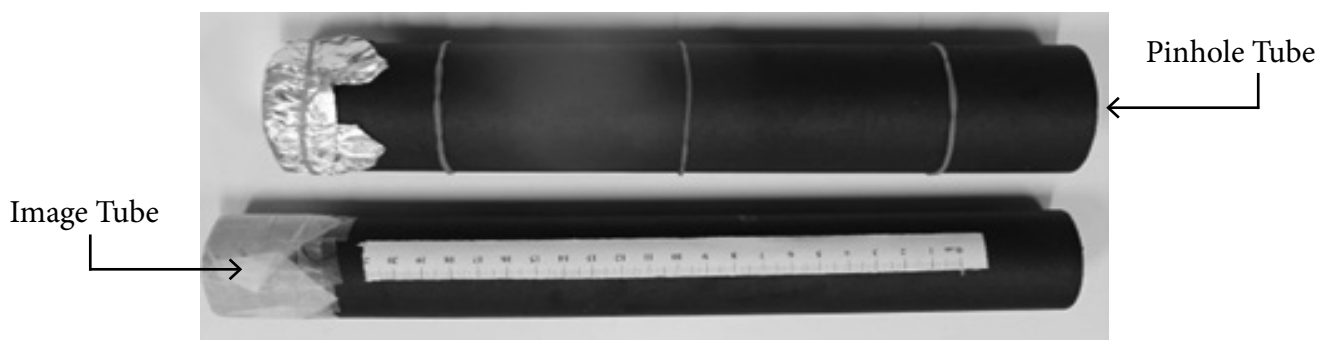

Figure 4 *Image Tube (IT) and Pinhole Tube (PT)*

- iv. Insert IT inside PT (as shown in figure 5) till the screen just touches the pinhole (refer figure 1). Mark a point 'O' on the IT where PT ends. Now take the IT out and stick a strip of white paper on it along its length (which is already done in figures 4 and 5). Taking point 'O' as zero, mark 5 mm intervals on the paper so that it can be used as a scale. [You may also use a printed scale, if available.] (Also refer to figure 9.) This scale will be used to measure ℓ , i.e., the distance between the screen and pinhole.

Now the pinhole camera is ready to use!

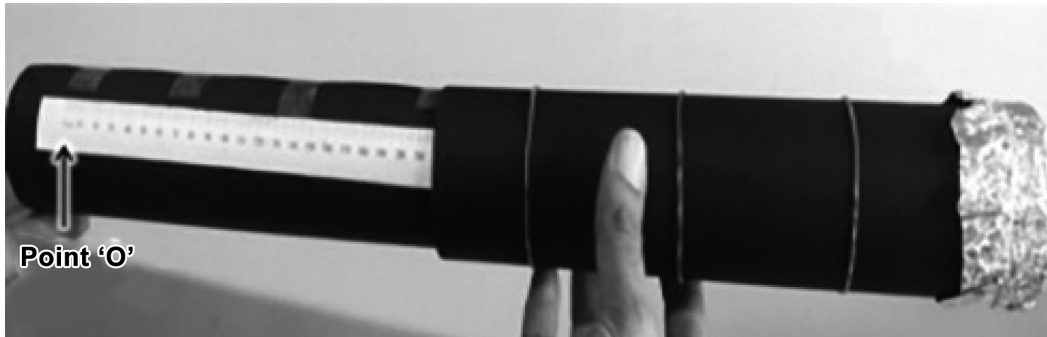

Figure 5 Assembling the camera

- v. To view an image, point the pinhole towards the object (the object should be brightly lit) and adjust the distance between the screen and the pinhole to view a clear image of the object on the screen. A picture of the Homi Bhabha Centre for Science Education building, Figure 6(a), when viewed through the pinhole is shown in Figure 6(b).



Figure 6(a) Object



Figure 6(b) Image in pinhole camera

Q1. What has changed from the object to the image? Can you describe the changes and think of reasons?

Q2. What happens to the image:

- i. if without changing the pinhole camera setting, you move further away from the object? Compare your image in terms of what view is covered now and before, size of image etc.

- ii. if you increase the distance between the pinhole and the screen?

- iii. if the illumination (brightness) of the object changes, or you look towards another object with lesser illumination?

Q3. Now explore what happens if the pinhole size is smaller and larger respectively. First, make some guess of how variation in the pinhole size will affect the image. [You may compare the same object with pinhole cameras of different groups, which may vary in pinhole size.]

Task 2: Constructing a model to explain the image formation in task 1

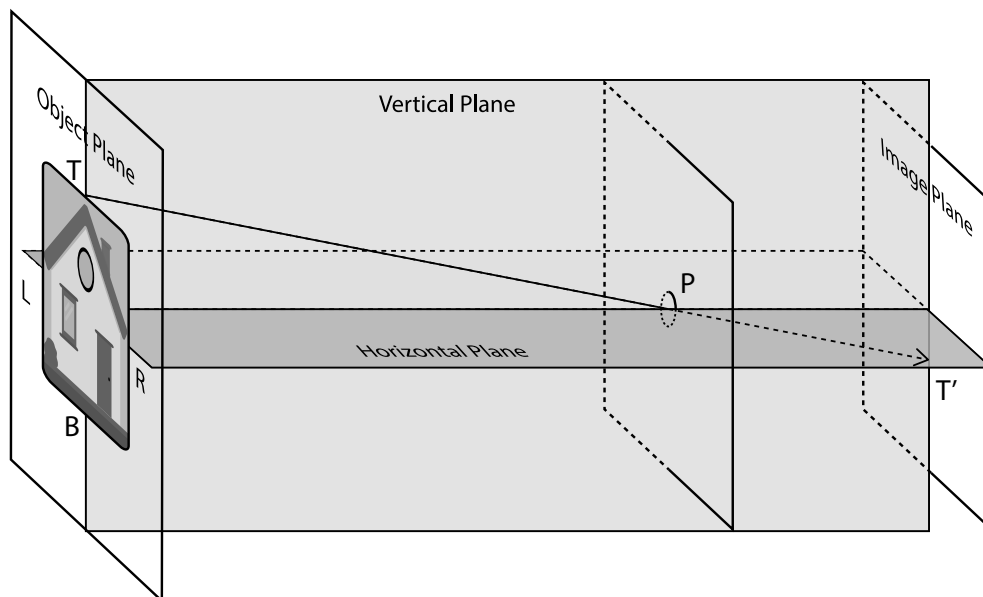

Figure 7 Draw rays originating from the object and falling on screen

Here our aim is to construct a geometrical model that would explain the image formation observed in task 1.

One of the understandings that evolved over the years is that when light travels in a medium of constant refractive index, it travels in a straight line. Therefore, the path of light is represented using a ray. You must have seen ray diagrams in your science book.

Q1. Let us try to draw a ray diagram to represent the image formation obtained in task 1. One ray TP starting from the top of an object which goes in a straight line towards the pinhole P will meet the screen at point T', as already drawn in figure 7. Can you draw three rays similar to TPT' originating from different points from the object in the figure?

Q2a. Refer to figure 8. Consider the ray ZPZ'. The ray starts from a green coloured point Z in the object. There is a brown coloured point at Q. What do you think will be seen at Z' in the image plane – a green dot or a brown dot? Similarly, suppose there is another ray QPQ'. What will you see at Q' in the image plane?

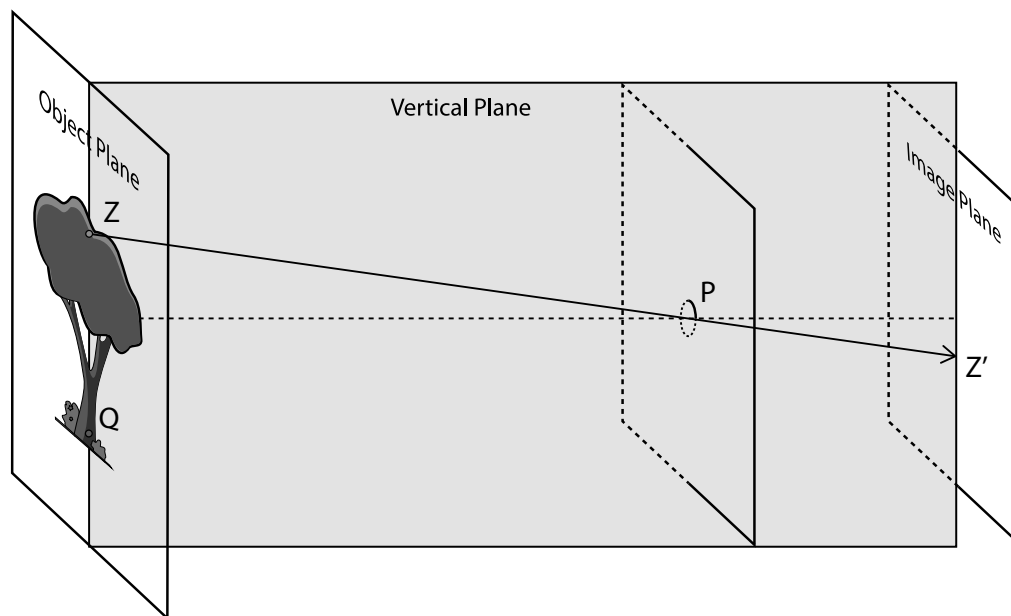

Figure 8 By drawing rays originating from the object, predict where green point (Z in the figure) and the brown point (Q in the figure) would be observed on the screen (image plane).

Q2b. Do you think there is a relation between the points on the object and the image plane? Discuss.

Q2c. Referring to figure 8, can you explain the orientation of the image observed?

Q2d. What should be be the light path if the image was to be of same orientation as the object? Check if this is observed in any of the pinhole cameras made by you or your friends.

Q3. Now, with the knowledge of light path discussed in the previous question, draw two rays in figure 8 which originate from the same point on the object, fall on the surface surrounding the pinhole (which acts as a blocking surface), and don't enter the hole. Where will these rays go?

Q4. If this blocking surface is removed, then where would these rays go? What would be the effects of these light rays on the image on the screen?

Q5. What do you think will happen to the image if the size of the pinhole is too big? Is your answer consistent with your observations in task 1?

Further questions to discuss: Based on the above model/representation of image formation, answer the following questions:

Q6. To get a clear image, why do you think object should be well-illuminated?

Q7. What do you think will happen to the image, if the size of the pinhole is too small? Is your answer consistent with your observations in task 1?

Task 3: Measuring the height of a very tall object

Pilot (Ideal scenario)

Figure 9 below shows the diagram for image formation in a pinhole camera.

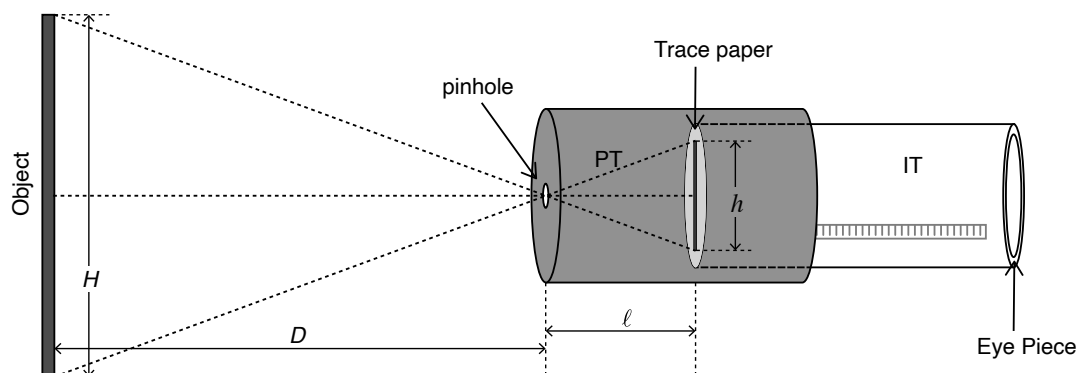

Figure 9 Schematic diagram of pinhole camera

You have to measure three quantities, distance (D) between pinhole and the object, screen-pinhole distance (ℓ), and size (h) of the image on the screen.

Once you know D , ℓ , and h you can find the height of the object H based on the following considerations. Consider the two triangles in figure 9 with shared vertex at the pinhole. Since they are similar triangles, $H/D = h/\ell$. Rearranging we get $H = hD/\ell$

You may use the formula directly at this point without deriving it but you might want to check the properties of similar triangles to learn how the formula is derived.

Working (real) example

Now, we will make use of this equation in a real-life example. Take your pinhole camera, and capture an image of a distant (well-illuminated) object such as a building or a tree. Measure D using a tape, measure ℓ using the scale on the inner tube, and h using the scale marked on the screen.

Obtain clear inverted image for multiple values of D . Tabulate your reading of D , ℓ and h below:

D (cm)	ℓ (cm)	h (cm)	$H = hD/\ell$ (cm)

Table 1

Average height of the object, (Mean) $H =$ _____

Q1. Can you estimate the height of the object by any other methods? Compare it with the answer you obtained using pinhole camera?

Discuss

Q2. If you want to see a bigger image on the screen (without changing the pinhole screen distance ℓ), should you move the pinhole closer to the object or farther away?

Q3. What will happen to the image if you make the screen using a transparent plastic sheet instead of translucent sheet?
